



# UG-ACTUATOR

## Hydraulic Powered Electric Actuator for Engine or Turbine Control

### APPLICATIONS

The UG-ACTUATOR offers the advantages of electronic control and load sharing systems while using the convenient, existing UG-8 type drives and linkages. The actuator provides the muscle for Woodward analog controls such as the 2301, as well as Woodward digital controls such as the 500-series and 700-series. The UG-ACTUATOR can be used with diesel, gasoline, or natural gas engines, and with steam and industrial gas turbines. The UG-ACTUATOR has a self-contained oil sump, so a separate oil supply is not required.

The actuator operates with a low speed pump for drive speeds from 375 to 1100 rpm, and with a high speed pump for 600 to 1500 rpm. An optional cooler is available for applications with a higher drive speed or high ambient temperature.

The UG-ACTUATOR is ideal for installations involving unattended starts.

The optional self-contained MPU simplifies the conversion of a UG-8 controlled engine or turbine to an electronically controlled engine. A gear which has been specifically designed to operate the MPU means that the electronic control will receive sharp, clean speed signals. Low speed applications may require override of the control's fail-safe during start-up.

### DESCRIPTION

The UG-ACTUATOR takes a given electrical input signal and converts it to a proportional hydraulic output-shaft position to control engine fuel flow. The standard UG-ACTUATOR produces approximately 20 J (15 ft-lb) of work over 42 degrees of rotary output.

A UG-8 drive in good condition makes an excellent MPU signal source. Alternatively, the UG-ACTUATOR is available with an LVDT for position feedback.

The UG-ACTUATOR uses the same cast-iron case as the UG-8 governor. The oil pump is the proven high-output Gerotor, designed to provide long life with minimal maintenance. The actuator uses standard UG-8 output shafts, power levers, power pistons, and piston links. The base is designed to precisely fit any drive designed for a UG-8 governor, and maintenance procedures are similar to those of the UG-8 governor.

The actuator's electric-to-hydraulic transducer uses a Woodward-built torque motor which converts the 20–160 mA control signal to a given output position.

- Proportional electrohydraulic actuator simplifies transfer from mechanical governing
- Economical installation using UG-8 case and drive
- Works with all Woodward 20–160 mA output electronic control systems
- Self-contained oil supply
- Integral magnetic pickup available

# SPECIFICATIONS

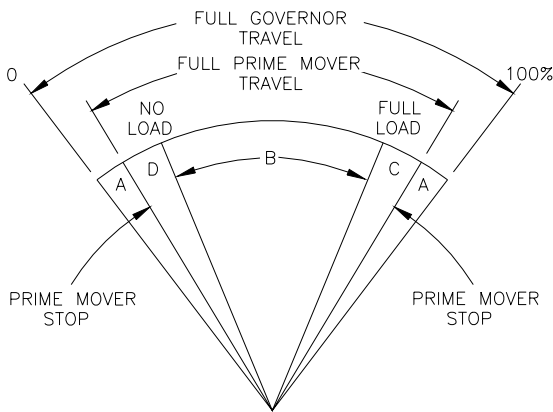

- A – Overtravel to insure prime mover stops are reached
- B – No load to full load travel – normally 2/3 of full governor travel is recommended
- C – Travel required to accelerate the prime mover
- D – Travel required to decelerate or shut down prime mover

375-090  
97-04-24

## Maximum Work Capacity (based on the full 42 degree travel of the output shaft)

Standard UG-ACTUATOR	19.4 J (14.3 ft-lb) in the increase direction; 23.3 J (17.2 ft-lb) in the decrease direction
20 ft-lb UG-ACTUATOR	27.2 J (20 ft-lb) in both directions
Remote UG-ACTUATOR	27.2 J (20 ft-lb) when supplied with 2760 kPa (400 psi); pressurized oil must be supplied to the actuator
Rated Work Capacity	2/3 of maximum work capacity

## Drive/Hydraulic Specifications

Drive Speed and Rotation	High Speed Pump: 600–1500 rpm Low Speed Pump: 375–1100 rpm Drive operates in one direction only.
Drive Power Requirement	375 W (0.5 hp) max.
Hydraulic Supply	Self-contained sump, 1.4 L (1.5 qt) capacity See Woodward Manual 25071, <i>Oils for Hydraulic Controls</i> , for specific recommendations. In most cases, the same type and weight of oils used in the engine can be used in the actuator.

## Control Qualities

Hysteresis	Within 3% of max. travel when measured over full 42 degrees of travel; Within 0.5% of max. travel when measured over 4% of full travel at 1 Hz
Temperature Drift	Nominally $\pm 1$ degree per 38 °C (100 °F)
Time Constant	70–90 ms for $\pm 50$ mA step with 1172 kPa (170 psi) actuator oil pressure
Linearity	Within 2.5% of full 42 degree output travel

## Electrical Specifications

Electrical Connector	3 pin: US MIL-STD 3102E-14S-7P 10 pin: US MIL-STD 3102E-18-1P (LVDT model)
Coil Resistance	23–26 $\Omega$ at 20 °C (68 °F)
Calibration	1–2 degrees at 20 mA 37 $\pm 2$ degrees from 20–160 mA Reaches maximum fuel at <200 mA

## Construction

Pump	Gerotor 3161 pump; relief valve set at 1172 kPa (170 psi)
Weight	16 kg (36 lbs)
Output Shaft	Standard: (2) 0.500-36 inch serrated Available: 0.625-36 serrated, or smooth shaft with a flat
Drive Shaft	Standard: 0.625-36 serrated
Other Available Drive Shafts	0.625 keyed drive shaft with 0.625-18 threads Extended 0.625 keyed drive shaft 1.125-48 shaft with adapter that fits PG base mounting hole pattern French standard BNA 227 NF-E22-151 0.16-31 drive shaft or RHD6

## Temperature Ranges

Ambient Operating Temperature	-29 to +93 °C (-20 to +200 °F)
Storage Temperature	-29 to +93 °C (-20 to +200 °F) (within the limits of the oil being used)

## Compliance

CSA	Class I, Division 2, Groups A, B, C, D (models available)
Vibration Resistance	Tested to US MIL-STD 810C, Curve D
Technical Manual	37512

PO Box 1519  
 Fort Collins CO, USA  
 80522-1519  
 1000 East Drake Road  
 Fort Collins CO 80525  
 Tel.: +1 (970) 482-5811  
 Fax: +1 (970) 498-3058

**Distributors & Service**  
 Woodward has an international network of distributors and service facilities. For your nearest representative, call the Fort Collins plant or see the Worldwide Directory on our website.

[www.woodward.com](http://www.woodward.com)

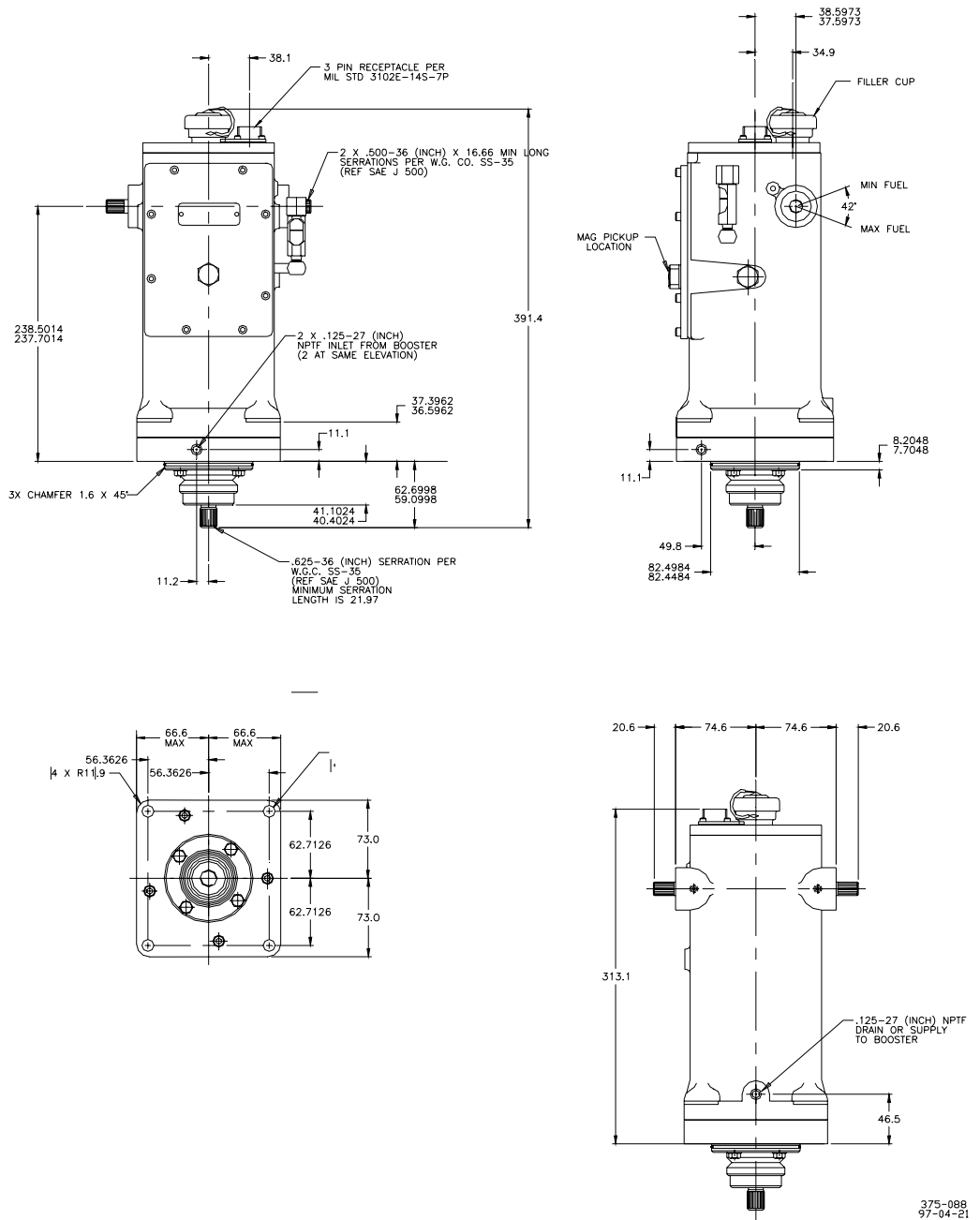

**Outline Drawing**  
 (Do not use for construction)

This document is distributed for informational purposes only. It is not to be construed as creating or becoming part of any Woodward Governor Company contractual or warranty obligation unless expressly stated in a written sales contract.

© Woodward 1991  
 All Rights Reserved

2007/1/Fort Collins

For more information contact: