

ProAct™ P-Series FL Position Controller

Electric Actuators with Integral Driver

Applications

The ProAct™ P-Series FL Position Controller is a family of electric actuators intended to be mounted on-engine to control varying functions including (but not limited to): fuel rack positioning, timing control, throttle valve, and wastegate positioning. The actuator is effectively a positioner which accepts a position command signal from another device in the system such as a speed control.

It includes an integral digital driver capable of controlling the actuator, communicating with the outside control system, and containing on-board software and intelligence to realize monitoring and customizing functions.

Description

The actuators are designed to be base- or flange-mounted (Model IV is base-mounted only) in an on-engine environment and can therefore withstand high levels of vibration and temperature extremes. They all have a 0.625-36 serrated tooth terminal shaft, and an optional rotation scale and indicator are available for visible travel detection. The actuators accept analog (jumper-selectable 0 to 5 Vdc, 4 to 20 mA, or 0 to 200 mA), CAN, or PWM position command signals and can be configured with a primary and backup position command signal input, providing redundancy with automatic failover and backup logic. It monitors all available internal and external signals, and annunciates any detected faults through a discrete output. An analog output (0 to 5 Vdc or 4 to 20 mA) provides actual position indication, and a discrete input is available to remotely shut down the actuator.

Additionally, the ProAct P-Series FL includes on-line and off-line diagnostics, current limiting based on driver electronics temperature, CAN communications, and service port communications. It is field programmable, allowing a single design to be used in many different applications. It must be configured and calibrated to the specific engine with a personal computer (PC) and a Woodward ProAct Service Tool that communicates serially to the driver via RS-232. The Service Tool (part number 9927-1187) can be downloaded from the Woodward website (www.woodward.com). Data files for subsequent applications of the same engine model can be downloaded off-engine.

Refer to manual 26659 for more detailed information.



- Extremely fast, bi-directional actuator, electronically positioned in both directions
- All-electric actuator requires no drive or hydraulic supply
- Integral driver compatible with broad range of control systems
- 75° ($\pm 2^\circ$) rotary output allows direct coupling to butterfly, eliminating linkage
- Multiple sizes to fit broad range of applications
- Single or redundant position command signals
- Configurable parameters to tailor to varied applications
- CAN communications
- Advanced Diagnostics

General Specifications

Actuator Model	Weight	Torque Output		Maximum Input Power		Maximum Current	
		Transient	Continuous	Transient	Continuous	Transient	Steady State
Model II	11 kg 25 lbs	5.2 N•m 46 lb-in	2.6 N•m 23 lb-in	251 W	65 W	13 A	3.5 A
Model III	15 kg 32 lbs	10.4 N•m 92 lb-in	5.2 N•m 46 lb-in	282 W	73 W	15 A	6.5 A
Model IV	24 kg 52 lbs	20.8 N•m 184 lb-in	10.4 N•m 92 lb-in	370 W	100 W	20 A	6.5 A

End User I/O Description

Power Input	18–32 Vdc with out-of-range diagnostics
Command Input	PWM: 8.4–32 V, 300 to 2000 Hz Analog: 0–200 mA, 0–25 mA, or 0–5 Vdc CAN
Position Feedback Output	0–25 mA or 0–5 Vdc
Discrete Inputs	Low Power standby mode Four CAN address combinations
Discrete Output	Normally “ON” turns “OFF” to indicate a detected fault
RS-232 Serial Communications	For connection to PC Service Tool
CAN 2.0B Communications	Complies with SAE J1939 but uses proprietary group extensions. Supports position command signal and monitoring of all shutdown and alarm conditions as well as some system variables.

Environmental Specifications

Specification Item	Acceptable Range or Qualification Condition	Comments
Operating Temperature Limits	–40 to +85 °C. Under all conditions the Temperature Monitoring Zone must remain below 90 °C.	See Mechanical Installation section of manual 26659 for discussion of this specification item.
Storage Temperature	–40 to +125 °C, unpowered.	
Mechanical Vibration	RV2: US MIL-STD-202F, procedure 214A: 0.1 G ² /Hz, 10 Hz to 2000 Hz, 3 hr/axis, 12.8 Grms	
Mechanical Shock	US MIL-STD-810C, Method 516.3, 516.4 procedure 1	
Ingress Protection	IP56 per IEC 60529	
Humidity	H2: (Woodward) profile	
Chemical Resistance	The actuator uses materials proven capable of withstanding normal engine environment chemicals per SAE J1455, such as diesel fuel, engine oil, and antifreeze.	

Performance Specifications

Parameter	Specification
Max Slew Rate	> 1000 degrees/second > 18.5 rad/s (10% to 90% travel)
Position Feedback Accuracy	< 1.0% of full stroke at 25 °C after calibration < 350 ppm/°C, maximum after calibration
Position Feedback Repeatability	< ±1.0% of full stroke at 25 °C after calibration

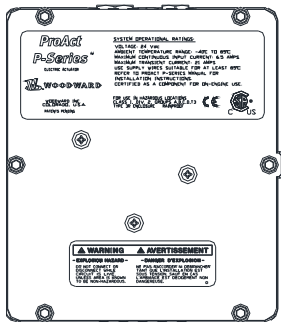

266-027
(9999-3139)
2012-4-26

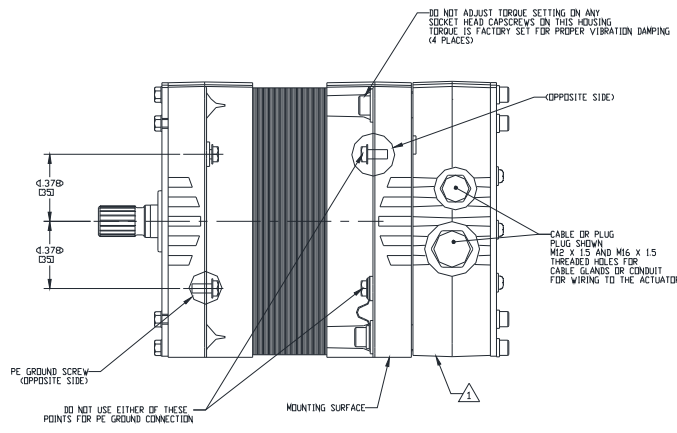
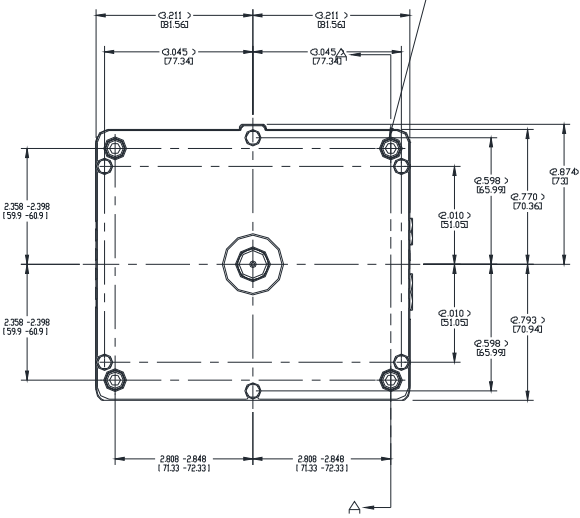
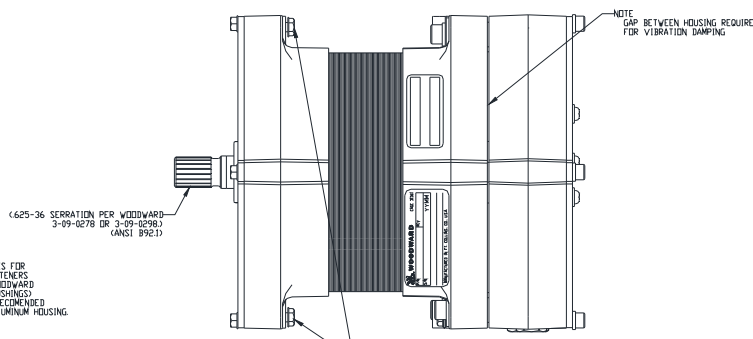
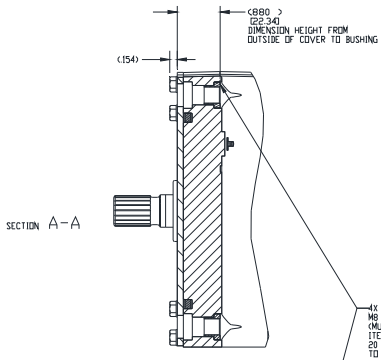

DIMENSION TABLE (BY MODEL)				
	A (INCH)	A (METRIC)	B (INCH)	B (METRIC)
MODEL II	2.182	(55.42)	(6.859)	(174.22)
MODEL III	3.395	(86.23)	(8.058)	(204.67)
MODEL IV	5.845	(148.46)	(10.509)	(266.93)

NOTES:
▲ A MINIMUM GAP OF 0.5MM MUST BE MAINTAINED AROUND THE ELECTRONICS ENCLOSURE AND ANY MOUNTING SURFACE AFTER INSTALLATION PER MANUAL.

DIMENSIONING FORMAT: INCH [METRIC]

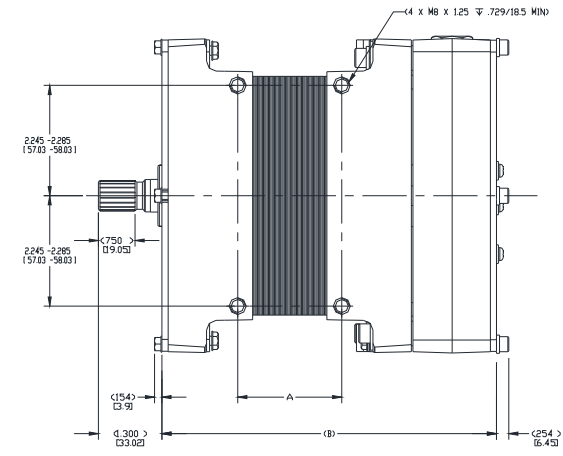

P-Series FL Position Controller Outline Drawing
(Do not use for construction)

Regulatory Compliance

European Compliance for CE Mark:

- EMC Directive: Declared to 2004/108/EC COUNCIL DIRECTIVE of 15 December 2004 on the approximation of the laws of the Member States relating to electromagnetic compatibility.

Other European Compliance:

- Machinery Directive: Compliance as partly completed machinery with Directive 2006/42/EC of the European Parliament and the Council of 17 May 2006 on machinery.

Agency Listings:

- CSA Certified for ordinary locations
- CSA Class I, Division 2 component listing

Customer Electrical Connections

All input and output signals run through an M12 and/or M16 threaded port, using cable glands and/or conduit as needed to maintain the Class I, Division 2 and Type 3R Enclosure Rainproof. Field wiring is connected to internal screwless cage-clamp-style terminal blocks.



PO Box 1519, Fort Collins CO, USA 80522-1519
1000 East Drake Road, Fort Collins CO 80525
Tel.: +1 (970) 482-5811 ♦ Fax: +1 (970) 498-3058
www.woodward.com

Distributors & Service

Woodward has an international network of distributors and service facilities. For your nearest representative, call the Fort Collins plant or see the Worldwide Directory on our website.

This document is distributed for informational purposes only. It is not to be construed as creating or becoming part of any Woodward contractual or warranty obligation unless expressly stated in a written sales contract.

Copyright © Woodward 2012, All Rights Reserved

For more information contact: