



EPG

Electrically Powered Governor Systems

- No mechanical drive or hydraulic supply required
- Up to 2.3 J (1.7 ft-lb) available work
- Accepts load sharing accessories
- 12 and 24 volt operation
- Single phase droop or isochronous control
- Switch-selected dual dynamics
- Start-fuel limit for smoke control
- EU Directive Compliant

DESCRIPTION

The 512/524 and 1712/1724 EPGs are three-component governing systems for 12 or 24 Vdc operation. All EPG systems include an actuator, an electronic speed control, and magnetic pickup.

Isochronous electronic controls are available with either start-fuel limit or with switch-selected dual dynamics.

Droop controls are available for certain types of parallel generator application. Load sharing devices are available for use with the isochronous models used in paralleled applications.

The selected EPG actuator is mounted on the prime mover and mechanically linked to the fuel control. The rotary design and output shaft on both ends gives 30° (512/524) or 35° (1712/1724) clockwise or counterclockwise travel to low-mass, low-friction fuel linkages. Preloaded internal return springs supply the shaft torque in the decrease-fuel direction and for shutdown should the electronic control signal be lost. A rugged cast aluminum housing permits installation of the speed control on the engine skid.

In operation, the control compares the speed of the engine with the desired speed or desired load and sets the actuator position to correct discrepancies.

Gain and stability adjustments tailor the governor's response to the specific engine. EPG controllers with switch-selected dynamics allow stable operation at no load and brisk response when the unit is heavily loaded.

APPLICATIONS

The EPG is designed for precise speed control of diesel, gas, gasoline engines, and gas turbines. The governor is especially suited to prime movers without a mechanical drive or hydraulic oil supply for the governor and which have low-mass, low-friction fuel linkages.

Controls are built with dynamics designed for specific engine applications.

Units with start fuel limit can prevent startup overspeed and excessive startup smoke. The start fuel limit is automatically removed when the engine nears selected speed.

The EPG is compatible with a full line of Woodward accessories providing for various levels of precision control of electrical generation or other processes.

Custom installation kits for a number of engines are available from Woodward.

An EPG system with position feedback from the actuator provides start-fuel limiting, actuator compensation, droop, and added stiffness.

A stronger 5.4 J (4 ft-lb) 4012/24 EPG system is described in Product Specification 82043.

OPTIONS

The single-phase droop speed control can load share in droop. The isochronous speed control can load share through the use of an accessory load sensor. If accessories are required with a droop system, use the isochronous speed control with a load sensor to provide droop.

Accessories for power systems that can be connected to the isochronous speed control include:

Generator Load Sensor

The Load Sensor is used with the isochronous speed control to provide droop or isochronous load-sharing capabilities. It allows the use of the SPM-A Synchronizer, Process and Import/Export Control, AGLC, or APTL (see Product Specification 82314).

SPM-A Synchronizer

Install the synchronizer for a fully automatic synchronizing, paralleling, and load-sharing system (see Product Specification 82383).

Ramp Generator

The Ramp Generator is connected to add linear ramp times of up to 25 seconds. For exponential ramp times up to four seconds, a capacitor can be connected to the EPG control (see Manual 82476).

Process and Import/Export Control

The Process and Import/Export Control maintains a certain flow, pressure, power, or other output of engines which drive pumps, compressors, or other mechanical or electrical loads. It can control inlet or exhaust pressure (see Product Specification 02013).

Automatic Generator Loading Control (AGLC)

Provides for soft loading or unloading of a generator set into or out of a load-sharing system at controlled rates. Tracks load to provide smooth transfer of power when loading or unloading. It requires a load sensor (see Product Specification 82399).

Automatic Power Transfer and Load Control (APTL)

The Automatic Power Transfer and Load Control can provide bumpless paralleling and adjustable speed ramps for loading and unloading the unit controlled by the EPG. The control allows peak shaving, import-export, and low and high limits for generator control. It requires a load sensor (see Product Specification 82380).

ACTUATOR SPECIFICATIONS

Output Shaft	0.375"-36 SAE serrated shaft on each end
Ambient Temperature Range	-40 to +93 °C (-40 to +200 °F)
Mounting	Mount in any configuration. The installation must not require lengths of wiring greater than those specified in the Maximum Wire Length chart.
Construction	Aluminum and steel parts. All parts treated for corrosion resistance. Not painted.
Work Output	Internal return springs provide operating force in the decrease-fuel direction. Additional, external spring must not be used.
Vibration	US MIL-STD-810C, method 514.2, procedure I, curve J per figure 514.2-2 except limited to 3 g.
Shock	US MIL-STD-810C, method 516.2, procedure I, figure 516.2-1, Ground Equipment test, 40 g input, 11 ms duration. A total of 18 terminal peak sawtooth shock pulses applied by the shaker machine, 6 in each axis, 3 in each direction (plus and minus).

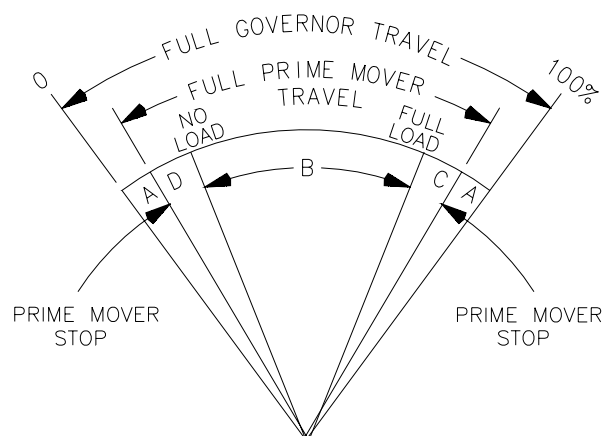

Maximum work capacities over full governor travel of 30° (512/524) or 35° (1712/1724) are: 512 = 0.7 J (0.5 ft-lb), 524 = 1.0 J (0.75 ft-lb), 1712 = 1.6 J (1.2 ft-lb), and 1724 = 2.3 J (1.7 ft-lb). See the chart to the left for recommended governor output travel. In special applications minimum and maximum prime-mover stops may be outside the governor stops.

A—Overtravel to ensure prime mover stops are reached
 B—No-load to full load travel—normally 2/3 of full governor travel is recommended
 C—Travel required to accelerate the prime mover
 D—Travel required to decelerate or shut down prime mover

EPG CONTROL SPECIFICATIONS

- 12 Volt Supply** 12 Vdc (10 Vdc minimum to 16 Vdc maximum) 60 W maximum power consumption. A battery charger must be capable of at least 7 A when the governor is energized.
- 24 Volt Control** 24 Vdc (20 Vdc minimum to 32 Vdc maximum) 95 W maximum power consumption. A battery charger must be capable of a least 5 A when the governor is energized.
- Fuse and Wiring** A 10 A slow-blow fuse or circuit breaker must be installed in the non-grounded battery lead. Route the battery leads directly to the speed control, not through any distribution points.
- Magnetic Pickup**..... Must provide 1.5 Vrms minimum and typically 100 Hz while cranking.
- Stability and Gain**..... These adjustments set the speed control's response to match the individual prime mover characteristics. Slow and fast response settings are provided with the dual-dynamics controller.
- Rated Speed** A 25-turn internal potentiometer sets rated speed.
- Idle Speed** A 50 kA potentiometer can be connected to set the idle speed between 25% and 100% of rated.
- Steady State Speed Band**..... The control typically maintains $\pm 1/4$ of 1% of rated speed.
- Ambient Temperature Range**..... -40 to +75 °C (-40 to +67 °F)
- Mounting** Engine skid mountable in any attitude. The installation must not require lengths of wiring greater than those specified in the Maximum Wire Length chart.
- Speed Trim (Optional)** A potentiometer can be connected to trim rated speed. Use a 1 kW potentiometer for a $\pm 2.5\%$ speed change. Use a 2 kW potentiometer for a $\pm 5\%$ speed change.
- Ramp Time, Idle/Rated (Optional)** Install a capacitor to add up to four seconds of acceleration and deceleration control. Use a Ramp Generator for longer times.
- Start Fuel Limit**..... Start Fuel Limit is adjusted with an internal 10-turn potentiometer. The limit sets the maximum terminal shaft position until 95% of the selected (idle or rated) speed is attained. Start Fuel Limit is re-established when the magnetic pickup frequency drops to 5% of rated speed or lower.
- Construction**..... The control box is constructed of cast aluminum and weighs about 0.5 kg (1 lb).
- Agency Qualified**..... EMC directive 89/336 EEC. Complies with EN50081-1, EN 50082-2.

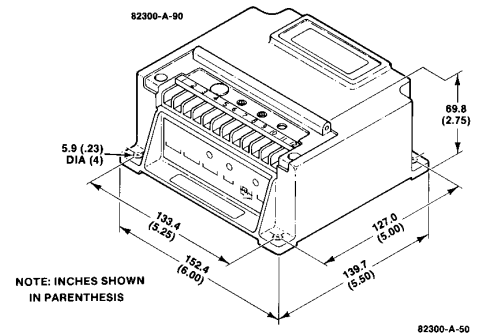
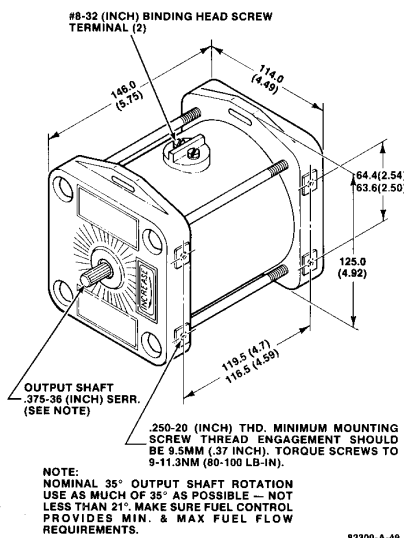
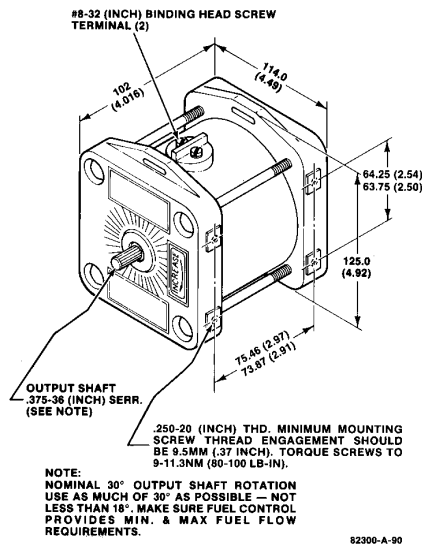

Outline Drawing
(Do not use for construction)

PO Box 1519
 Fort Collins CO, USA
 80522-1519
 1000 East Drake Road
 Fort Collins CO 80525
 Ph: +1 (970) 482-5811
 Fax: +1 (970) 498-3058

Distributors & Service

Woodward has an international network of distributors and service facilities. For your nearest representative, call the Fort Collins plant or see the Worldwide Directory on our website.

Corporate Headquarters

Rockford IL, USA
 Ph: +1 (815) 877-7441

www.woodward.com

EPG PART NUMBERS**Actuator**

Model 512, 12 Vdc	8256-022
Model 524, 24 Vdc	8256-021
Model 1712, 12 Vdc	8256-017
Model 1724, 24 Vdc	8256-016

Actuator with Sealed Position Feedback

Model 512, 12 Vdc w/Position Feedback–CCW output w/MS3102R-14S-7P Receptacle	8256-089
Model 524, 24 Vdc w/Position Feedback–CW output w/MS3102R-14S-7P Receptacle	8256-086
Model 524, 24 Vdc w/Position Feedback–CCW output w/MS3102R-14S-7P Receptacle	8256-087
Model 1712, 12 Vdc w/Position Feedback–CW output w/MS3102R-14S-7P Receptacle	8256-084
Model 1712, 12 Vdc w/Position Feedback–CCW output w/MS3102R-14S-7P Receptacle	8256-085
Model 1724, 24 Vdc w/Position Feedback–CW output w/MS3102R-14S-7P Receptacle	8256-078
Model 1724, 24 Vdc w/Position Feedback–CCW output w/MS3102R-14S-7P Receptacle	8256-079

Speed Control (Isochronous)

The following part numbers represent a 3000–6000 Hz range; contact Woodward Governor Company for part numbers of different speed ranges.

12 Vdc, 512 or 1712 SC for Diesel or Turbine, w/Start Fuel Limit	8290-186
12 Vdc, 512 or 1712 SC for Natural Gas or Gasoline, w/Start Fuel Limit	8290-187
24 Vdc, 524 or 1724 SC for Diesel or Turbine, w/Start Fuel Limit	8290-184
24 Vdc, 524 or 1724 SC for Natural Gas or Gasoline, w/Start Fuel Limit	8290-185

Speed Control (Droop) For 512/524 and 1712/1724 Series Systems

The following part numbers represent a 3000–6000 Hz range; contact Woodward Governor Company for part numbers of different speed ranges.

12 Vdc, Diesel or Turbine	8290-192
24 Vdc, Diesel or Turbine	8290-191
24 Vdc, Natural Gas or Turbine	8290-045

Speed Control With Position Feedback

24 Vdc, 524 or 1724 Speed Control, Diesel or Natural Gas Engines	8290-103
24 Vdc, 4024 Speed Control, Diesel or Natural Gas Engines	8290-149

EPG Actuator Driver For EPG Actuator with Position Feedback

The following part numbers represent the controls that drive the EPG 512/524, 1712/1724 and 4024 Actuators with a 1–5 Vdc, 4–20 mA, or 20–160mA signal source.

12 Vdc, 512 or 1712 Actuator Driver, 1–5 Vdc or 4–20 mA input	8290-136
12 Vdc, 512 or 1712 Actuator Driver, 20–160 mA input	8290-135
24 Vdc, 524 or 1724 Actuator Driver, 1–5 Vdc or 4–20 mA input	8290-133
24 Vdc, 524 or 1724 Actuator Driver, 20–160 mA input	8290-134
24 Vdc, 4024 Actuator Driver, 1–5 Vdc or 4–20 mA input	8290-153

This document is distributed for informational purposes only. It is not to be construed as creating or becoming part of any Woodward Governor Company contractual or warranty obligation unless expressly stated in a written sales contract.

For more information contact: