



ACTIVGEN™

Engine Speed Control

Applications

Woodward's ACTIVGEN™ engine speed control was designed specifically for use on Caterpillar diesel engines equipped with ADEM™ electronic control modules, and can markedly improve the transient response of Caterpillar generators in load-sharing applications.

The ACTIVGEN control does not replace the ADEM control; rather it is used as a separate, external primary speed control with user-configurable PID settings. The ACTIVGEN control gives the user full access to tune the Caterpillar engine directly (rather than needing a CAT technician to make tuning changes in the ADEM unit), which can save time and expense during commissioning. The ACTIVGEN control frees the user to make regular "maintenance" tuning adjustments over time to maintain optimum system performance as operating conditions change.

The ACTIVGEN control interfaces easily with secondary paralleling genset controllers, such as the Woodward easYgen™-3000 series. Communication between the ACTIVGEN control and secondary paralleling genset controllers is done over a CAN network using the standard SAE-J1939 protocol. CAN-based digital communication provides an advantage over analog bias signals by allowing the secondary paralleling control to be mounted in the switchgear, far from the generator skid, while decreasing vulnerability to noise interference commonly experienced on analog bias lines.

The ACTIVGEN control uses the same Woodward ToolKit programming software as the easYgen controllers, making commissioning and tuning of parallel systems quicker and easier when the two controllers are used together.

Description

To improve dynamic response and simplify the commissioning process, Caterpillar offers an option in the ADEM called Direct Fuel Control (DFC). Once enabled, DFC allows an external speed control (the ACTIVGEN) to control fuel to diesel engines directly, based on a PWM input to the ADEM. The DFC option is available across multiple Caterpillar platforms, from the C27 to the CM product lines. DFC only disables the speed governing function of the ADEM; engine protection and other functions are retained, and it does not affect emissions.

The ACTIVGEN control works with the ADEM unit to provide accurate fuel control in order to maintain constant engine rpm. The ACTIVGEN control allows the user to properly tune the dynamics of the engine to provide stability at steady state and optimum response to large load steps, ensuring smooth synchronization, reduced engine hunting, and improved load sharing.

The ACTIVGEN control is housed in a robust enclosure and can be mounted directly on the engine skid, providing reliable control under extreme operating conditions.



- Take control of commissioning Cat® ADEM™-equipped gensets
- Improve steady-state and transient dynamics in load-sharing systems
- Full user access to primary speed control PID settings for optimal tuning
- Decrease commissioning time and expense
- CAN/J1939 bus interface with secondary paralleling genset controllers, such as the easYgen™ control
- Isochronous speed control
- Easy access to PID settings with ToolKit calibration software

Controller Specifications

Electrical

Operating Voltage	9–32 Vdc
12 Vdc Supply Voltage	9–16 Vdc
24 Vdc Supply Voltage	18–32 Vdc

Environmental

Ambient Operating Temperature	(–40 to +85) °C / (–40 to +185) °F
Ambient Storage Temperature	(–40 to +105) °C / (–40 to +221) °F
Vibration	7 Grms
Shock	1 meter drop on concrete
EMC	Tests based on JASO-D001-94 ISO 7637, ISO-10605, ISO-11452, CISPR 25 / ISO 13766, and EN-61000
Enclosure	Weatherproof case and sealed connectors. Rated to IP67
Calibration	Requires standard serial cable and software for calibration (Woodward ToolKit)
Mounting	Off engine and away from exhaust manifold and pipes
Weight	Approx. 0.5 kg / 1.2 lb

Controller Dimensions

Dimensions in brackets are in millimeters

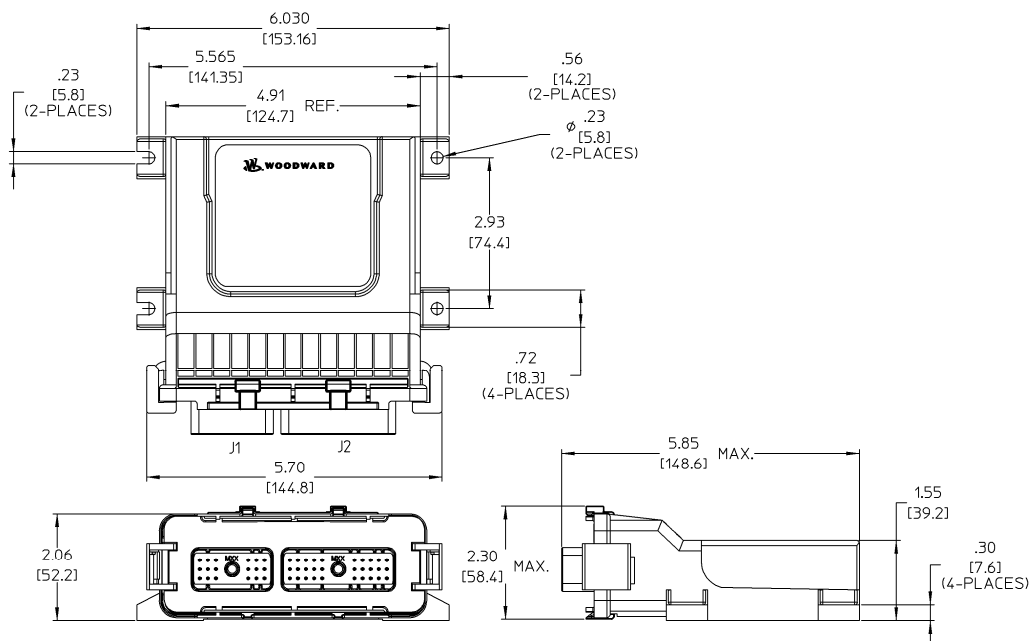

ACTIVGEN Engine Speed Control

Controller Features

- CAN/J1939 bus interface is used to command engine speed.
- Calibration is simple, using the Woodward ToolKit service tool. The controller can be calibrated on any IBM-compatible PC, allowing for easy customization and re-programmability.
- Speed input uses a magnetic pickup.

Programmable Features

- Isochronous speed governing.
- PID gain adjustment allows governor response to be adjusted by user.
- Input and output circuit diagnostics protect the inputs and outputs from failure due to compromised field wiring.

System Control Example

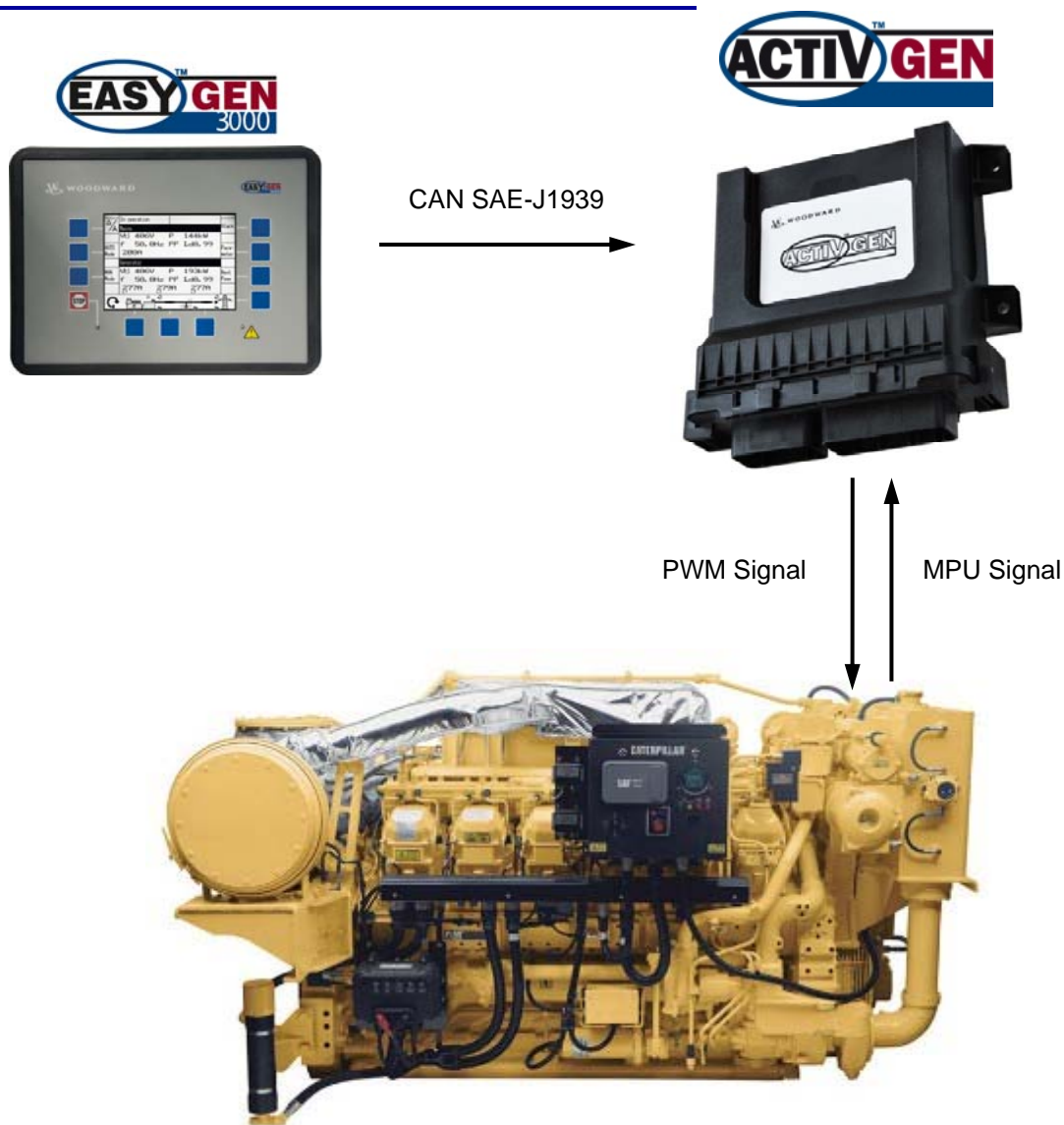

Calibration

The actiVgen controller is configured using Woodward's ToolKit software, which can be downloaded from www.woodward.com/software. This calibration tool monitors system operation and assists in diagnosis of system faults. It is also capable of monitoring all sensor inputs, control outputs, and diagnostic functions through a single access point to the controller.

The recommended computer and system software to support ToolKit is:

- IBM-compatible personal computer equipped with a CD-ROM drive and a serial port with DB-9 connector capable of 38,400 baud communication
- Microsoft Windows® 2000 / XP / Vista / NT 4.0 Service Pack 6a
- Microsoft .NET Framework Version 2.0
- 96 MB of available RAM memory and a hard disk with at least 2.0 megabytes of free disk space
- SVGA-capable video card and monitor, capable of 256 colors and 800 x 600 display
- Serial port and standard serial communication cable

Ordering Information

Description	Item Number
ACTIVGEN Controller	8440-2100



PO Box 1519, Fort Collins CO 80522-1519, USA
 1000 East Drake Road, Fort Collins CO 80525, USA
 Phone +1 (970) 482-5811 • Fax +1 (970) 498-3058
 Email and Website—www.woodward.com

Woodward has company-owned plants, subsidiaries, and branches, as well as authorized distributors and other authorized service and sales facilities throughout the world. Complete address / phone / fax / email information for all locations is available on our website.

This document is distributed for informational purposes only. It is not to be construed as creating or becoming part of any Woodward contractual or warranty obligation unless expressly stated in a written sales contract.

Copyright © Woodward 2013, All Rights Reserved

For more information contact: